

Cell Specification

INR 21700 62E1

Powerful for you.
Fast for everyone.



E-Mobility



Industrial



Medical



Power- and
Gardentools



Drive
System



Energy Storage
Systems

INR 21700 62E1

Cylindrical Lithium Ion Cell

1. Scope

The product specification describes the requirements of the Cylindrical Lithium-ion Cell to be supplied to the customer by TerraE. Should there be any additional information required by the customer, customer are advised to contact TerraE.

2. Description and Model

2.1 Description	Cylindrical Lithium Ion Cell
2.2 Model	INR_21700_62E1

3. General Specifications

3.1 Nominal Capacity	6050mAh (at 0.2C Discharge)
Minimum Capacity	5850mAh (at 0.2C Discharge)

Nominal capacity is measured by the discharge at 0.2C to 2.5V end voltage after standard fully charged according to specification at 25°C.

3.2 Maximum Charge Voltage	4.20V
3.3 Average Working Voltage	3.60V
3.4 Standard Charge Method (25°C ± 2°C)	CC-CV to 4.2V 0.5C (3025mA)
3.5 Maximum Charge Current	0.7C (at 25°C, not ideal for cycle life)

Recommended charge rates

0°C ≤ T ≤ 5°C	0.1C (605mA)
5°C < T ≤ 10°C	0.5C (3025mA)
10°C < T ≤ 15°C	0.5C (3025mA)
15°C < T ≤ 25°C	0.7C (4235mA)
25°C < T ≤ 45°C	0.7C (4235mA)

3.6 Standard Discharge	Constant Current (CC)	1.0C (6050mA)
	Current	2.5V
	End Voltage	

3.7 Maximum Discharge Current	2C (at 25°C, not ideal for cycle life)
--------------------------------------	--

Recommended discharge rates

-20°C ≤ T < 25°C	1.0C (6050mA)
0°C ≤ T < 35°C	2.0C (12100mA)
35°C ≤ T < 45°C	1.0C (6050mA)
45°C ≤ T < 60°C	0.5C (3025mA)

INR 21700 62E1

Cylindrical Lithium Ion Cell

3.8	Cycle Life	70% SOH after 600 cycles at 25°C with 0.5C/1C	
3.9	Weight of Bare Cell	≤75g	
3.10	Operating Environmental Temperature	Charge	0°C ~ 45°C
		Discharge	-20°C ~ 60°C
3.11	Storage Temperature (For Shipping State)	1 month	-20°C ~ 40°C
		3 months	-20°C ~ 40°C
		12 months	-20°C ~ 20°C

4. Outline Dimension (Unit: mm)

Dimension: Diameter max 21.85mm, Height max 71.15mm. Refer to the attached drawing 1.

5. Appearance

There shall be no such defect as deep scratch, flaw, crack, rust, leakage, which may adversely affect commercial value of the cell.

6. Test condition and definitions

6.1 Measuring Equipment

6.1.1	Electronical Balance	Parameter mileage 0.01g-160g, accuracy 1mg
6.1.2	Manual Voltage-Impedance Tester	Impedance: Parameter mileage 0-3.1kΩ, accuracy 0.1μΩ, The impedance meter should be operated at AC 1kHz
6.1.3	Digital Caliper	Parameter mileage 0-150mm, accuracy ± 0.02mm, resolution ratio 0.01mm

6.2 Unless otherwise specified, all tests shall be performed at 25°C ± 2°C and humidity of 65%RH ± 20%RH. The cells used for the test mentioned should be new ones delivered a week before at most.

6.3 Definition

C Rate ("C"):

The rate (milliamperes) at which a fully charged cell is discharged to its end voltage in one (1) hour.

7. Characteristics

7.1 Charge Method

7.1.1 Charging shall consist of charging at a 0.5C constant current rate until the cell voltage reaches 4.2V. The cell shall then be charged at constant voltage of < 4.2V while tapering the charge current. Charging shall be terminated when the charging current has tapered to 0.02C.

INR 21700 62E1

Cylindrical Lithium Ion Cell

7.2 Discharge Method

7.2.1

Cells shall be discharged at a constant current of 0.2C to 2.5 volts

7.2.2

Cells shall be discharged at a constant current of 0.5C to 2.5 volts

7.2.3

Cells shall be discharged at a constant current of 1.0C to 2.5 volts

7.2.4

Cells shall be discharged at a constant current of 2.0C to 2.5 volts

7.2.5

If the voltage of an individual cell falls below 2.5V, it is deemed to be in a state of over-discharge and is no longer usable.

7.3 Internal Impedance

The impedance shall be measured by 6.1.2

Initial Internal Impedance $\leq 25\text{m}\Omega$

7.4 Internal Impedance

Cells shall be charged per standard charge method at $25^\circ\text{C} \pm 2^\circ\text{C}$ and discharged per 7.2.1 (0.2C), 7.2.2 (0.5C), 7.2.3 (1C), 7.2.4 (2C).

The discharge capacity of each cell at respective discharge rate shall be compared with the discharge capacity at 0.2C and the percentage shall be calculated. Each cell shall meet or exceed the requirements of Table 1.

Discharge Current	Available Capacity
0.2C	100%
0.2C	$\geq 95\%$
0.2C	$\geq 93\%$
0.2C	$\geq 90\%$

7.5 Cycle Life

Charge 0.5C constant current charge to 4.20V followed by 4.20V constant voltage charge to cut-off current $\leq 0.1\text{ C}$ (550mA). Discharge: 1C constant current discharge to cut-off voltage $\leq 2.75\text{V}$.

Discharge capacity (600th Cycle) $\geq 70\%$ of 1st Cycle Capacity.

7.6 Storage Characteristics

7.6.1

After charge as per standard charge method 7.1.1, store the testing cells at $25^\circ\text{C} \pm 2^\circ\text{C}$ for 28 days. Then discharge as per 7.2.3. Then the same cell is fully charged as per 7.1.1 again and discharged a second time and measured as per 7.2.3. Then discharge as per 7.2.3. Then the same cell is fully charged as per 7.1.1 again and discharged a second time and measured as per 7.2.3. The recovery discharge capacity (3rd discharge capacity) $\geq 90\%$ of Initial capacity.

INR 21700 62E1

Cylindrical Lithium Ion Cell

7.6.2

After charge as per standard charge method 7.1.1, store the testing cells at $55^{\circ}\text{C} \pm 2^{\circ}\text{C}$ for 7 days. Then discharge as per 7.2.3. Then the same cell is fully charged as per 7.1.1 again and discharged a second time and measured as per 7.2.3. Then discharge as per 7.2.3. Then the same cell is fully charged as per 7.1.1 again and discharged a second time and measured as per 7.2.3. The recovery discharge capacity (3rd discharge capacity) $\geq 90\%$ of Initial capacity.

7.7 Temperature Characteristics

Cells shall be charged with 0.5C and discharged with 1C.

Temperature	Available Capacity
-20°C	$\geq 70\%$
-10°C	$\geq 75\%$
0°C	$\geq 85\%$
10°C	$\geq 90\%$
45°C	$\geq 97\%$
60°C	$\geq 98\%$
25°C	100%

8. Safety

8.1 External Short-Circuiting Test at 25°C

Cell, charged per standard charge method, is to be short circuited by connecting the positive (+) and negative (-) terminals with a total external resistance of $< 5\text{m}\Omega$. Stop the test after 10 minutes. The cell shall be observed for 1 hour afterwards.

Criteria: No Fire, No Explosion

8.2 Overcharge Test

Cell, charged per standard charge method, is to be over-charged with 1C for 1 hour or the cell voltage reaches 6.3V while tapering the charge current. The cell shall be observed for 1 hour afterwards.

Criteria: No Fire, No Explosion

INR 21700 62E1

Cylindrical Lithium Ion Cell

8.3 Overdischarge Test

Cell, charged per standard charge method, is discharged at constant current of 1C for 90min. The cell shall be observed for 1h afterwards.

Criteria: No Fire, No Explosion, No Leakage

8.4 Heating Test

Cell, charged per standard charge method, is to be placed in the hot oven. Store the testing cells connecting with thermocouple in constant temperature box, heating the cells and box (speed of ascending temperature is $5^{\circ}\text{C} \pm 2^{\circ}\text{C}$ per min) together at room temperature simultaneously, monitor the temperature change of the box, keep for 30 minutes after the box temperature reaches $130^{\circ}\text{C} \pm 2^{\circ}\text{C}$, then stop the test. The cell shall be observed for 1 hour afterwards.

Criteria: No Fire, No Explosion

8.5 Drop Test

Cell, charged per standard charge method, is to be immersed completely in 3.5wt%NaCl solution for 2 hours. The cell shall be observed for 1 hour afterwards.

Criteria: No Fire, No Explosion

8.6 Seawater Immersion Test

Cell, charged per standard charge method, is to be dropped with both ends from a height of 1.0 meter onto the cement floor. The cell shall be observed for 1 hour afterwards.

Criteria: No Fire, No Explosion

8.7 Low Pressure Test

Cell, charged per standard charge method, is to be put at a pressure of 11.6kPa at room temperature for 6 hours. The cell shall be observed for 1 hour afterwards.

Criteria: No Fire, No Explosion, No Leakage

9. Packaging

Loading 100 cells per box, refer to attachment 2.

10. Others

Any matter not included in this specification shall be conferred between the both parties.

11. Shipping

The cell voltage in delivery is between 3.30V – 3.80V, or in accordance with customers' requirement. The remaining capacity before charging shall be changed depending on the storage time and conditions.

INR 21700 62E1

Cylindrical Lithium Ion Cell

Attached 1: Cell Size Drawing

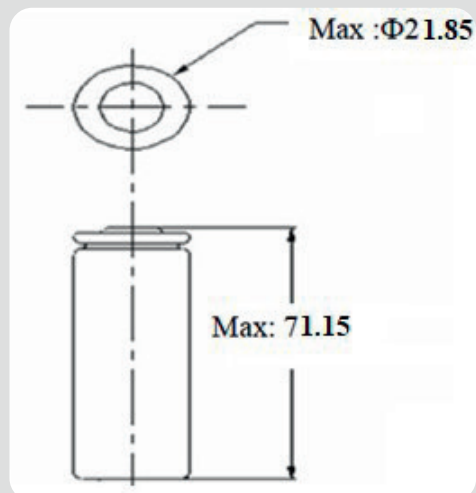

Attached 2: Packaging per box

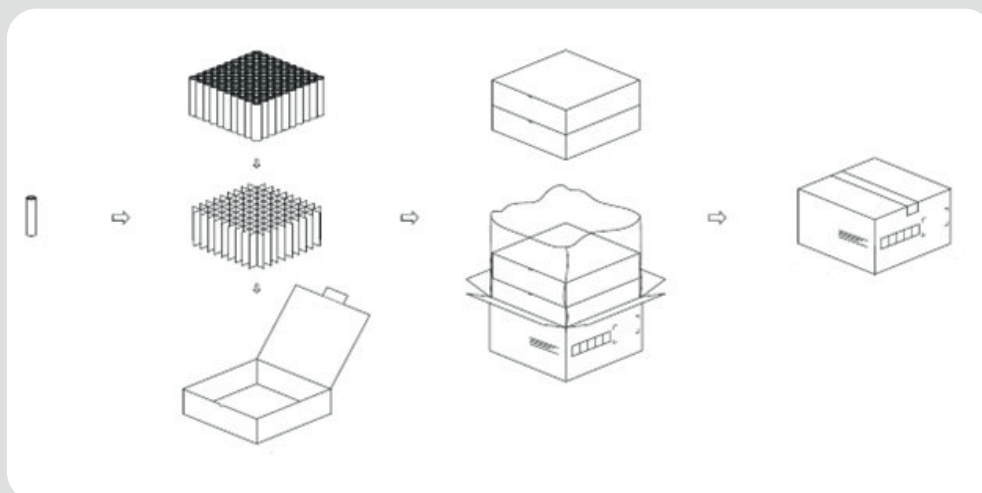

INR 21700 62E1

Handling Instructions

The following caution and warning should appear in manuals and/or instructions for users, especially at the point of use.

Handling Instructions for Lithium Ion Rechargeable Cell

1. Charging Electric Car, Charger and Battery Pack Design Considerations

1.1 Charging

- 1.1.1** The cell must undergo charging using a combination of constant current and constant voltage methods. The charging voltage for a single cell must not surpass 4.20V, and the cut-off charging current should be equal to or greater than 1/50C (110mA). Taking into account the charger's control deviation, the cell's charging voltage should be kept below 4.20V. In exceptional cases, the charging voltage must not exceed 4.25V to prevent overcharging. It's important to note that a charging voltage higher than 4.20V will result in a reduced cycle-life for the cell.
- 1.1.2** The charger needs to incorporate a pre-charging system, which serves to prevent excessively high power charging following a deep discharge. In instances where the cell voltage drops below 2.5V (0% State of Charge) due to long-term storage, it is necessary to pre-charge the cell using a current lower than 0.1C until the voltage rises above 2.5V. Once this threshold is reached, the charger can switch to the standard charging mode. However, if the cell voltage fails to reach 2.5V within a 30-minute timeframe, the charger must automatically cease the charging process.
- 1.1.3** Chargers should be equipped with a complete charge detection device. The charging detection device can be checked by timer, current detection or open circuit voltage detection to detect the charging state. When the charging detection device detects that the cell is fully charged, the charging circuit should be completely cut off to avoid trickling charge. The cell charge should be carried out at the temperature of 0°C ~ +45°C. When the cell temperature exceeds this range, it should be placed until the cell temperature reaches the above range.
- 1.1.4** For cycle life, use the normal charging method with recommended currents.

INR 21700 62E1

Handling Instructions

1.2 Discharging

- 1.2.1 Single cell discharge current should be less than maximum discharge current.
- 1.2.2 The discharge cutoff voltage of the cell shall be higher than 2.5V;
- 1.2.3 The discharge temperature of the cell range from -20°C to +60°C. During the discharge process, if the surface temperature of the cell exceeds 70 °C, the discharge must be terminated.
- 1.2.4 If the voltage of a single cell is lower than 2.5V, the cell is considered to be over discharged and cannot be used anymore.

1.3 Storage

Any storage, cell should be in low humidity (less than 45%RH), no corrosive gas atmosphere area. And there is no press and condensation on the cell. Best temperature range -20°C ~ 20°C. For long storage, the soc of the cell must between 10% ~ 35% SOC, and the voltage of the cell must be checked before used.

When stored within 1 month: -20°C ~ 40°C

When stored within 3 months: -20°C ~ 40°C

When stored within 12 months: -20°C ~ 20°C

1.4 Precautions on Battery Pack Design

1.4.1 Battery pack Shape, Mechanism and Material

The battery pack should be designed so that it cannot be charged by an unauthorized charger. The battery pack design should ensure that it does not connect to unauthorized equipment. The positive and negative ends of the battery pack should be designed to avoid short circuit or reverse connection. In addition, the battery pack should have an overcurrent protection device to avoid the occurrence of external short circuit. There should be no overlap between the positive and negative connection wires of the battery pack. The battery pack should be designed to prevent static electricity and dust, liquids, etc. The battery pack should be designed to consider that the electrolyte will not reach the protective circuit board even if the cells leakage happen. The design of the battery pack should ensure that the cells are fixed in the battery pack and not arbitrarily movable. The battery pack shall be structurally designed to prevent the occurrence of dents, deformations or other mechanical stresses on the cells in the event of a predictable fall. The flammability of materials used in the battery pack, such as double-sided tape and rubber, should be verified.

INR 21700 62E1

Handling Instructions

1.4.2 Battery pack structure (battery pack limits the number of batteries used)

The number of parallel connections is unlimited, but the battery pack must pass the overcharge test (the charging current of the overcharge test is the product of the maximum charging current of the charger and the number of parallel connections). The number of serial connections is unlimited, and series fuses are required. The cell should be kept away from heating electronic components to avoid deterioration of cell performance. Insulation should be provided between the PCB'A and the battery pack (e.g. plastic barrier for air isolation or non-thermal conductive insulation).

1.4.3 Protection Circuit insure safety of battery

The following protection circuit should be installed in the battery pack:

Over charge protection

For safety reasons and in order not to shorten cycle life, the maximum overcharge protection voltage of the single cell in each module should be less than 4.2V.

Over discharge protection

If the single cell voltage reaches 2.5V, TerraE recommends that the discharge current should be cut off by over discharge protection circuit, and the consumption current of the protection circuit should be no more than 100 μ A.

Over current protection

If the discharge current of a single cell exceeds about maximum discharge current, the overcurrent protection should cut off the discharge current.

Protection circuit power consumption:

In order to avoid over discharge mode in long-term storage, the current consumption of the battery pack protection circuit should be set as small as possible. When it is not in use for a long time, it is necessary to check the residual state of the cell regularly and ensure that each single cell in the battery pack cannot reach the over-discharge state.

1.4.4 Cell connection

The cells cannot be connected using soldering process. In order to avoid any damage, resistance welding or laser welding is recommended for cell connection. Cells in battery pack should be temperature balanced. When the battery pack is discharging, the internal temperature difference of the battery pack should be less than or equal to 5°C.

INR 21700 62E1

Handling Instructions

1.5 Cell Usage

- 1.5.1 When the cell is used in tandem, the same grade, the same batch and the same charging state are necessary. This information can be obtained from the label of the inner and outer box. Before the cell is used, the voltage, internal resistance should be detected and assembled according to its purpose. TerraE suggests that the cell voltage within 20 mV and the internal resistance difference within 6mΩ should be guaranteed at least.
- 1.5.2 Check voltage, internal resistance, protection circuit function, thermistor, thermal fuse of battery pack before shipment.
- 1.5.3 Special attention should be paid to the transfer of the cell to the assembly plant. External damage caused by the transport process is forbidden. TerraE recommends using the same transport packaging, even if the packaging is opened during the process.
- 1.5.4 Do not use damaged or leaking cells which caused by transportation damage, drop, short circuit or other reasons.

1.6 Quality assurance immunity

- 1.6.1 Within one year of normal use, any quality problem caused by any manufacturing process, other than abuse, shall be solved by the manufacturer. Outside this period, the reason is not the manufacturing process but the cell quality problem caused by customer misuse. TerraE does not promise free replacement.
- 1.6.2 When conducting resistance welding and laser welding of cells, it is necessary to conduct DOE process experiment and confirm welding parameters. TerraE is not responsible for the safety problems related to internal damage of the cell caused by improper welding.
- 1.6.3 TerraE shall not be liable for any loss caused by violation of the specifications;
- 1.6.4 TerraE will not be responsible for any problems caused by design defects of battery packs and chargers;
- 1.6.5 TerraE does not accept abnormal cells due to improper assembly.
- 1.6.6 TerraE is not responsible for spot welders

2. Safety Instructions

Batteries containing organic solvents and other flammable substances, such as improper use may cause the core heat or fire, resulting in damage to the battery or personal injury. Please pay attention to the use of prohibited items, while the protection device should be added to avoid the use of equipment caused by abnormal batteries accident. Before using lithium-ion rechargeable batteries, please read the following safety guidelines carefully. In addition it is strongly recommended to add these instructions to the user manual.

2.1 Dangerous Matter

- 2.1.1 Don't use or place batteries in high temperature (above 70°C) environment. Do not put it into fire, water or make it moisture. Do not repair or disassemble batteries, there is a risk of causing the batteries to ignite, overheat, leak or explode.

INR 21700 62E1

Handling Instructions

- 2.1.2** Don't place the batteries in a chaotic manner, away from metal and other conductive materials to avoid positive (+) negative (-) short circuit, do not reverse the positive (+) negative (-) pole
- 2.1.3** Don't use non-specified charging equipment and violate charging requirements. Non-specified conditions charge will cause the battery to overcharge or abnormal chemical reactions, heat generation, smoke, rupture or fire.
- 2.1.4** Don't connect the battery to the AC plug (outlet) or the car plug. The battery needs to have a specific charger. If the battery is connected directly to the plug, the battery may catch fire, smoke, explode, or cause heat.
- 2.1.5** Don't overcharge, over-discharge, drive nail into the cell, strike it by hammer or tread and step on it.
- 2.1.6** Don't hit or throw batteries. If the batteries appear to fall, please treat the waste, cannot continue to use.
- 2.1.7** Don't dissect the battery. If the protection line is damaged, the battery will no longer be protected. Then, the battery may fire, smoke, explode or cause heat.
- 2.1.8** Don't charge near high temperatures. If the battery is charged near the high temperature, the battery cannot be recharged due to the protection line. In this case, the protection circuit may be interrupted, the battery may fire, smoke, explode or cause heat.
- 2.1.9** Don't use batteries that are clearly damaged or deformed. May cause fever, smoke, rupture or burning.
- 2.1.10** Don't direct soldering of batteries, overheating will lead to insulation gaskets and other parts of the deformation, causing cell deformation, leakage, explosion or fire.
- 2.1.11** Don't reverse polarity charge. In the case of charging, the battery is reverse charging will be abnormal chemical reaction. In addition, there is an unpredictable high current through the discharge. These may cause heat, smoke, rupture or burning.

2.2 Warning

- 2.2.1** Batteries should be kept away from infants and young children. In case of swallowing the battery, please seek medical attention immediately.
- 2.2.2** Don't place the battery in a microwave oven or other cooking utensils. Due the heating and electrical shock of the microwave oven, the battery may ignite, smoke, explode or cause heat.
- 2.2.3** Don't mix with other batteries. The battery cannot be mixed with other different capacities, chemical systems, or manufacturers' batteries. Do not connect other batteries or mix other batteries. The battery may catch fire, smoke, explode or cause heat.
- 2.2.4** Don't use an abnormal battery. If there are obvious abnormalities, such as odor, fever, deformity or discoloration, stop using the battery. Such batteries may be defective and, if used, may cause fire, smoke, heat or explosion.

INR 21700 62E1

Handling Instructions

- 2.2.5 If the charging process does not end, stop charging. If the battery cannot complete the charging process for a specified period of time, stop the charging step. The battery may catch fire, smoke, explode or cause heat.
- 2.2.6 Don't use a leaky battery near a flame. If the battery or liquid out of the battery produces a pungent odor, the battery should remain away from the flame. The battery may be ignited or exploded.
- 2.2.7 Don't touch the leaky battery. If the liquid leaking from the battery into the eyes, will cause serious damage. If you come from your leaked liquid into your eyes, rinse your eyes with water immediately. Please consult a doctor immediately. If the liquid is left in the eyes, it will cause serious damage.
- 2.2.8 In order to avoid short circuit or damage, please tightly put the battery into a box or carton.
- 2.2.9 Don't store the cell in a pocket or a bag together with metallic objects such as keys, necklaces, hairpins, coins, or screws.

2.3 Precautions

- 2.3.1 Don't use or place batteries in high temperature environments, such as in direct sunlight. The battery may catch fire, smoke, explode or cause heat. At the same time, may cause battery performance and life degradation.
- 2.3.2 Battery pack has a protective line. Do not use batteries in places where static electricity (over 100V) is generated, which may damage the protection circuit. If the protective line of the battery is damaged, the battery may catch fire, smoke, explode or cause heat. Do not use Lithium ion cell with the primary batteries or secondary batteries whose capacity or kinds or maker is different. If do that, the cell will be discharged or charged excessively in use. And it may cause the generating heat, smoke, rupture or flame because of the abnormal chemical reaction in cells.
- 2.3.3 Do not charge the battery outside the specified temperature range. Failure to do so may result in heat, leakage, or serious damage. In addition, battery performance and life degradation may occur.
- 2.3.4 Please read the manual before use. Please keep this manual for future reference.
- 2.3.5 Please read the charging method of the charger manual.
- 2.3.6 In the first use, if the battery has an abnormal smell, heat or rust, please contact the supplier.
- 2.3.7 Keep away from flammable materials during charging and discharging. May cause fire, smoke, explode or cause heat.
- 2.3.8 If the electrolyte leaks from the battery, gets on the clothes or on the skin, rinse it immediately with water. Other- wise it may irritate the skin.
- 2.3.9 If wires or metal objects come out of the battery, completely seal and insulate them. Otherwise, the battery may cause a short circuit, fire, smoke, explosion, or cause heat.
- 2.3.10 After use, please carry out battery recycling according to local laws and regulations.

INR 21700 62E1

Handling Instructions

3. Exclusion Liability

- 3.1 TerraE is not liable for any loss caused by breach of notice in the specification
- 3.2 TerraE is not responsible for any problems caused by design defects in battery packs, electric cars and chargers
- 3.3 TerraE does not accept abnormal batteries caused by improper assembly
- 3.4 TerraE is not liable for any loss caused by incorrect or incongruent with the SPEC charge and discharge method and inappropriate environment
- 3.5 TerraE is not liable for any force majeure (ex. Lightning, storm, flood, fire, earthquake, etc)
- 3.6 In order to standardize the use of sample batteries, the rights, obligations and responsibilities of every customer and TerraE are clarified. Before using the battery, please read carefully and thoroughly understand the contents of the specification. In order to ensure the safety of the battery, please contact TerraE to discuss design of the application. Also, if there are special usage conditions (for example: a large current load, a quick charge method, or a special usage pattern), please consult TerraE before finalizing the product specification. If you choose to use this battery, your use will be regarded as an endorsement of all the contents of this statement. The amendment, renewal and final interpretation of this statement are belong to TerraE.

Any questions?

Contact us, we will be pleased to advise you.

A full load of advantages

Customized cells tailored to your individual requirements with the best choice in Li-Ion technology for the coming development.



One-Stop Shop



Customized



High Quality





More Power



High Energy

Headquarter Germany

TerraE GmbH
Zeche Gustav 1
63791 Karlstein am Main

 +49(0) 6188-9956-0
 info@terrae.com
 www.terrae.com

Power – the result of a better battery